

inspiring the  
**World Of Wireless...**



# TR-900 GSM/GPRS Module

## Product Technical Specifications

*(For firmware version AU.001.1.0.0)*

Date : 15 October 2008  
Document Version : 3.1  
Our Reference : 02000B22

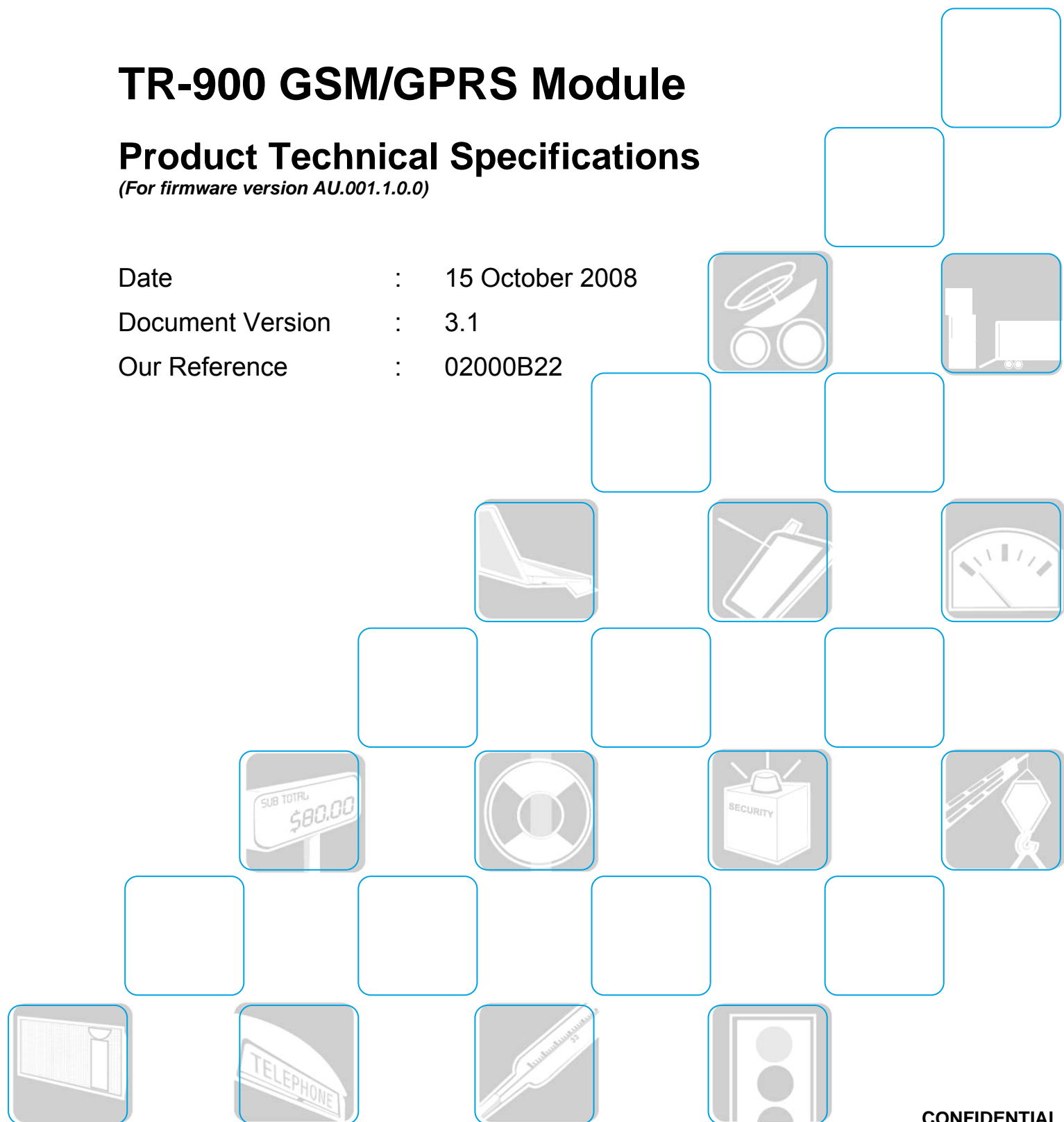

## Document History

Revision	Date	Document History	Associated Firmware Version
-	04 Feb 08	<ul style="list-style-type: none"> <li>▪ Draft</li> </ul>	P1
av1.0	09 May 08	<ul style="list-style-type: none"> <li>▪ Alpha Version Release</li> </ul>	P2
bv2.1	29 May 08	<ul style="list-style-type: none"> <li>▪ Beta Version Release</li> <li>▪ Updated GPIO_1, LPG and GPIO_4 pin assignment</li> </ul>	P2
3.0	01 Sep 08	<ul style="list-style-type: none"> <li>▪ Commercial Release</li> <li>▪ Updated on contents and electrical characteristics in               <ul style="list-style-type: none"> <li>○ Board-to-board interfaces</li> <li>○ Power Supply and Ground</li> <li>○ Analog to Digital Converter (ADC)</li> <li>○ ON/OFF Control</li> <li>○ Reset Pin</li> <li>○ VIO Digital Supply Output</li> <li>○ Subscriber Identity Module (SIM) Interface</li> <li>○ Analog Audio Interfaces</li> <li>○ Digital Audio Interface</li> <li>○ Light Pulse Generator (LPG)</li> <li>○ Keyboard Interface</li> <li>○ 2-Wire Serial Interface</li> <li>○ Serial Parallel Interface</li> <li>○ RF Connections</li> </ul> </li> <li>▪ Updated "Interfaces" in chapter "General Information"</li> <li>▪ Added Buzzer as alternate function for Pin 20 (GPIO_3) in Chapter "Pin Description"</li> <li>▪ Highlighted firmware customization needed for:               <ul style="list-style-type: none"> <li>○ Digital Audio Interface</li> <li>○ Buzzer</li> <li>○ Battery Charging Interface</li> <li>○ SPI with 2 Addresses</li> <li>○ 2-Wire Bus</li> </ul> </li> </ul>	P3
3.1	15 Oct 08	<ul style="list-style-type: none"> <li>▪ Added block diagram</li> <li>▪ Updated information on power consumption</li> <li>▪ Updated TR-900 mechanical drawing</li> </ul>	P4

## GENERAL NOTE

The aim of this document is to support the application and engineering efforts of iWOW's customers. This document is intended for testing, evaluation, integration, and information purposes.

iWOW makes every effort to ensure that the quality of the information is available. The content of this documentation is provided on an "as is" basis and may contain deficiencies or inadequacies.

iWOW disclaims any warranty and all responsibility for the application of the device(s) that is made in relation to the accuracy, reliability or contents of this document. iWOW is not liable for any injury, loss or damage of any kind incurred for the use of or reliance upon information.

iWOW reserves the right to make any modifications, additions and deletions to this document due to typographical errors, inaccurate information, or improvements to products at any time and without notice.

## TABLE OF CONTENTS

<b>1</b>	<b>INTRODUCTION.....</b>	<b>1</b>
1.1	Reference Documents .....	1
1.2	Abbreviations .....	1
1.3	Type Approvals .....	3
1.4	Safety Precautions .....	4
<b>2</b>	<b>SPECIFICATIONS .....</b>	<b>6</b>
2.1	General Specifications .....	6
2.2	GSM/ GPRS Specifications .....	6
2.3	Interface Specifications .....	7
2.4	Memory .....	8
<b>3</b>	<b>TR-900 SYSTEM ARCHITECTURE.....</b>	<b>9</b>
<b>4</b>	<b>INTERFACES .....</b>	<b>10</b>
4.1	General-Purpose Connector (GPC).....	10
4.2	Power Supply and Ground .....	10
4.2.1	Power Consumption.....	11
4.3	Backup Power Supply .....	12
4.4	Battery-Charging Interface (BCI) .....	13
4.5	Analog to Digital Converter (ADC).....	13
4.6	ON/OFF Control .....	14
4.6.1	State Transitions .....	15
4.6.2	Switch-On Condition .....	15
4.6.3	Switch-Off Condition .....	15
4.7	Reset Signal .....	16
4.8	VIO Digital Supply Output .....	16
4.9	Subscriber Identity Module (SIM) Interface.....	17
4.9.1	SIM Detection.....	17
4.10	Serial Link (UART) Interfaces .....	18
4.10.1	UART – Modem port .....	18
4.11	USB Interface.....	19
4.11.1	USB Boot .....	19
4.12	Analog Audio Interfaces .....	20
4.12.1	Microphone input.....	20
4.12.2	Earphone.....	21
4.12.3	Speaker.....	22
4.13	Digital Audio Interface .....	23



4.14	Light Pulse Generator (LPG) .....	23
4.15	General Purpose Input Output (GPIO).....	24
4.16	Keyboard Interface.....	25
	4.16.1 Implementation of a 5x5 keyboard.....	26
4.17	2-Wire Serial Interface .....	27
4.18	Serial Parallel Interface.....	28
	4.18.1 SPI Address 0 .....	28
	4.18.2 SPI Address 1 .....	28
4.19	Buzzer Interface .....	29
4.20	RF interface.....	29
	4.20.1 Connections .....	29
	4.20.2 Coaxial Receptacle .....	29
	4.20.3 RF Pad for Coaxial Cable .....	29
	4.20.4 RF Performance.....	30
<b>5</b>	<b>PINS DESCRIPTION .....</b>	<b>31</b>
<b>6</b>	<b>60-PIN CONNECTOR.....</b>	<b>33</b>
<b>7</b>	<b>MECHANICAL DRAWING .....</b>	<b>34</b>
<b>8</b>	<b>SUPPORT/ CONTACT US .....</b>	<b>35</b>
	<b>APPENDIX A: RELIABILITY TEST SPECIFICATION .....</b>	<b>36</b>

## 1 INTRODUCTION

This document describes the hardware interface, including interface specifications, electrical and mechanical details, of the TR-900 GSM/GPRS module that connects to the cellular device application.

### 1.1 Reference Documents

S/N	Document	Our Reference
1	TR-900 AT Commands Guide	02000B23
2	TR-900 Multisocket Internet Connection AT Commands Guide	02000B24
3	TR-900 Module Migration Guide	02000B28

### 1.2 Abbreviations

The following abbreviations are used in this document:

Abbreviation	Description
ACM	Accumulated Call Meter
ADC	Analog Digital Convertor
AMR	Adaptive Multi-rate
AMR- FR	AMR Full-rate
AMR-HR	AMR Half-rate
AND	Abbreviated Dialing Number
AOC	Advice of Charge
APN	Access Point Name
AT	ATtention
CLIP	Calling Line Identity Presentation
CSD	Circuit Switched Data
CUG	Closed User Group
DCD	Data Carrier Detect

DCE	Data Communication Equipment
DCS	Data Coding Scheme
DSR	Data Set Ready
DTE	Data Terminal Equipment
DTMF	Dual Tone Multi Frequency
DTR	Data Terminal Ready
EFR	Enhanced Full-rate
FR	Full-rate
GPIO	General Purpose Input Output
GPRS	General Packet Radio Service
GSM	Global Standard for Mobile Communications
HR	Half-rate
IP	Internet Protocol
kbps	kilo bit per second
MO	Mobile Originator
MS	Mobile Station
MT	Mobile Terminal
PDP	Packet Data Protocol
PDU	Packet Data Unit
PIN	Personal Identification Number
PPP	Point-to-Point Protocol
RF	Radio Frequency
RTS	Ready To Send
SAR	Specific Absorption Rate
SIM	Subscriber Identification Number
SMS	Short Messages Service
TCP	Transmission Control Protocol
TE	Terminal Equipment
UART	Universal Asynchronous Receiver Transmitter
UDP	User Data Protocol
USSD	Unstructured Supplementary Service Data

### 1.3 Type Approvals

This product, together with its evaluation board, has been certified for compliance with the directives and standards listed below:

Directive	Description
99/05/EC	“Directive of the European Parliament and of the council of 9 March 1999 on radio equipment and telecommunications terminal equipment and the mutual recognition of their conformity”, in short referred to as R&TTE Directive 1999/5/EC
ETSI EN 301 489-1 V1.6.1 (2005-09) / EN301 489-7 V1.3.1 (2005-11)	Candidate Harmonized European Standard (Telecommunications series)  Electro Magnetic Compatibility and Radio spectrum Matters (ERM); Electro Magnetic Compatibility (EMC) Standard for Radio Equipment and Services; Common Technical Requirements  Part 7: Specific conditions for mobile and portable radio and ancillary equipment of digital cellular radio telecommunications systems (GSM and DCS)
ETSI EN 301 511 V9.0.2	“V7.0.1 (2000-12) Candidate Harmonized European Standard (Telecommunications series) Global System for Mobile communications (GSM); Harmonized standard for mobile stations in the GSM 900 and DCS 1800 bands covering essential requirements under article 3.2 of the R&TTE directive (1999/5/EC) (GSM 13.11 version 7.0.1 Release 1998)”
EN60950-1:2006	Safety of information technology equipment
EN 50383 / EN 50385	Basic standard for the calculation and measurement of electromagnetic field strength and SAR related to human exposure from radio base stations and fixed terminal stations for wireless telecommunications system  Product Standard to Demonstrate the Compliances of Radio Base Stations and Fixed Terminal Stations for Wireless Telecommunication Systems with the Basic Restrictions or the Reference Levels Related to Human Exposure to Radio Frequency Electromagnetic Fields (110 MHz - 40 GHz)
2002/95/EC	RoHS Directive – Compliance Test

GCF	Global Certification Forum – Compliance Test
PTCRB	PCS Type Certification Review Board
3GPP TS 51.010-1	“Digital cellular telecommunications system (Phase 2); Mobile Station (MS) conformance specification”
FCC	Code of Federal Regulations (CFR Title 47), Part 15, Part 22 and Part 24; US Equipment Authorization FCC

## 1.4 Safety Precautions

For your own safety, please follow the safety precautions listed below during all phases of the operation, usage, service or repair of any cellular terminal or mobile incorporating the TR-900 GSM/GPRS Module. All manufacturers of these cellular terminals or mobile devices are advised to include the following safety precautions into all manuals provided with their terminal or mobile device, and pass this information to device users and operating personnel. Failure to comply may be dangerous or illegal.

### Road safety

Do not use a mobile device while driving. Park the vehicle first or use a hand free earphone. It is illegal in some countries to use a mobile device while driving.

### Switch off in aircraft

Cellular terminal or mobile devices can cause interference to aircraft electronics. Using them on aircraft is both illegal and dangerous.

### Switch off when refueling vehicle

Do not use the cellular terminal or mobile device at a refueling station or near fuels or chemicals.

### Forbidden Usage

Always switch off your cellular terminal or mobile device where it is forbidden to be used in any areas like a hospital.

### Interference

All cellular terminals or mobile devices may be subjected to radio interference, which could affect their performance.

### **Emergency calls**

As the GPRS/GSM module is based on GSM standard for radio signals and cellular networks, this connection cannot be guaranteed at all times under all conditions. It should never be entirely relied upon for essential communications such as an emergency call.

### **Note on compliance with international rules and regulations**

The TR-900 module is a fully certified GSM/GPRS engine. The module has been tested and certified for compliance to international safety and GSM standard requirements at the modular level.

Manufacturers of cellular terminal or mobile equipment incorporating the TR-900 are advised to test their final products to ensure compliance to these EMC tests/requirements:

- ESD
- Radiated Spurious Emissions
- Conducted Emissions, if applicable
- Further tests if applicable

The module was not assessed against the essential requirement 'health'. Manufacturers of the final products are also responsible to ensure that their products are tested for compliance to any other health requirements that might be applicable.

A few other important notes regarding safety in implementation and usage of the module:

- The module shall be supplied by a Limited Power Supply (LPS) according to EN60950:2000.
- No necessary spacing (creepage and clearance distance) shall be reduced by installing the module into the final equipment.
- Provisions shall be made for fastening the module securely in the end product.

Instructions and equipment markings related to safety shall be in a language, which is acceptable in the country in which the equipment is to be installed.

## 2 SPECIFICATIONS

### 2.1 General Specifications

Feature	Description
Network Type	Quad-Band GSM/GPRS
Frequency Bands	Quad Band: GSM850 / EGSM900 / DCS1800 / PCS1900
Output Power	<ul style="list-style-type: none"> <li>• GSM 850 / EGSM 900 : Class 4 (2W)</li> <li>• DCS1800 / PCS1900: Class 1 (1W)</li> </ul>
AT Command Interface	<ul style="list-style-type: none"> <li>• Compliant to GSM 07.05 and GSM 07.07 recommendations</li> <li>• iWOW Proprietary AT Commands</li> </ul>
Physical Dimensions	<ul style="list-style-type: none"> <li>• Dimensions: 38 x 31 x 3mm</li> <li>• Weight: 6.4g (including of shielding)</li> </ul>
Environmental	<ul style="list-style-type: none"> <li>• Normal Operating Temperature: -20° C to +55° C</li> <li>• Extended Operating Temperature: : -40° C to +85° C (not fully compliant to ETSI Spec Compliant)</li> <li>• Storage Temperature: -40° C to +85° C</li> </ul>

### 2.2 GSM/ GPRS Specifications

Feature	Description
GSM Audio	<ul style="list-style-type: none"> <li>• Telephony</li> <li>• Emergency call</li> <li>• Half Rate, Full Rate and Enhanced Full Rate (HR/FR/EFR)</li> <li>• Adaptive Multi-rate (AMR)</li> <li>• Hands-Free Operation</li> <li>• Echo Cancellation (Enhanced AEC)</li> <li>• Noise Reduction</li> <li>• DTMF (encoding only)</li> </ul>
Circuit Switched Data (CSD)	<ul style="list-style-type: none"> <li>• Asynchronous, Transparent &amp; Non-Transparent</li> <li>• Max speed: up to 14.4kbps</li> </ul>
Fax	<ul style="list-style-type: none"> <li>• Group 3, Class 2.0</li> </ul>
SMS	<ul style="list-style-type: none"> <li>• Point-to-point (MO/MT)</li> <li>• Cell Broadcast</li> </ul>

	<ul style="list-style-type: none"> <li>• Text and PDU mode</li> </ul>
Supplementary Services	<ul style="list-style-type: none"> <li>• Call Forwarding, Barring, Waiting, Hold</li> <li>• Multiparty</li> <li>• Advice of Charge (AoC)</li> <li>• Calling Line Identification Presentation (CLIP)</li> <li>• Calling Line Identification Restriction (CLIR)</li> <li>• Unstructured Supplementary Services (USSD)</li> <li>• Closed User Group (CUG)</li> </ul>
GPRS	<ul style="list-style-type: none"> <li>• Multislot Class 10</li> <li>• Mobile Station Class B</li> <li>• Coding Schemes CS1 – CS4</li> <li>• PBCCH Support</li> <li>• PCCCH Support</li> <li>• PPP Stack</li> </ul>

### 2.3 Interface Specifications

Feature	Description
60-pin Board-to-Board Connector	<ul style="list-style-type: none"> <li>• Power Supply</li> <li>• Back-up Battery</li> <li>• Keyboard</li> <li>• 1 Serial Link</li> <li>• USB 2.0</li> <li>• 3V/1.8V SIM</li> <li>• SIM Detection</li> <li>• GPIOs</li> <li>• Activity Status Indication</li> <li>• Analog to Digital Converter</li> <li>• Digital* &amp; Analogue Audio</li> <li>• Reset</li> <li>• Power On</li> <li>• Buzzer*</li> <li>• Battery Charging Interface*</li> <li>• SPI with 2 Addresses*</li> <li>• 2-Wire Bus*</li> </ul>

Others	<ul style="list-style-type: none"><li>• UMC Antenna Connector and Antenna Pad</li><li>• On-Board SIM holder (Optional)</li></ul>
--------	--

*\* This feature is not enabled in the standard module firmware as it requires a certain level of firmware customization depending on the customers' intended application. Please contact iWOW for more information on this interface.*

## 2.4 Memory

- Quad Band:
  - On-Board Flash: 64Mb
  - RAM: 16Mb

RF functionalities comply with the GSM Phase 2 recommendations. The frequencies covered are:

- |                                 |                               |
|---------------------------------|-------------------------------|
| • Tx GSM850: (824 ~ 849 MHz)    | Rx GSM850: (869 ~ 894 MHz)    |
| • Tx EGSM900: (880 ~ 915 MHz)   | Rx EGSM900: (925 ~ 960 MHz)   |
| • Tx DCS1800: (1710 ~ 1785 MHz) | Rx DCS1800: (1805 ~ 1880 MHz) |
| • Tx PCS1900: (1850 ~ 1910 MHz) | Rx PCS1900: (1930 ~ 1990 MHz) |

**Note:** All Pin Voltage not specified are supplying at nominal 1.8V.

Please refer to Appendix A for reliability test specification.

### 3 TR-900 SYSTEM ARCHITECTURE

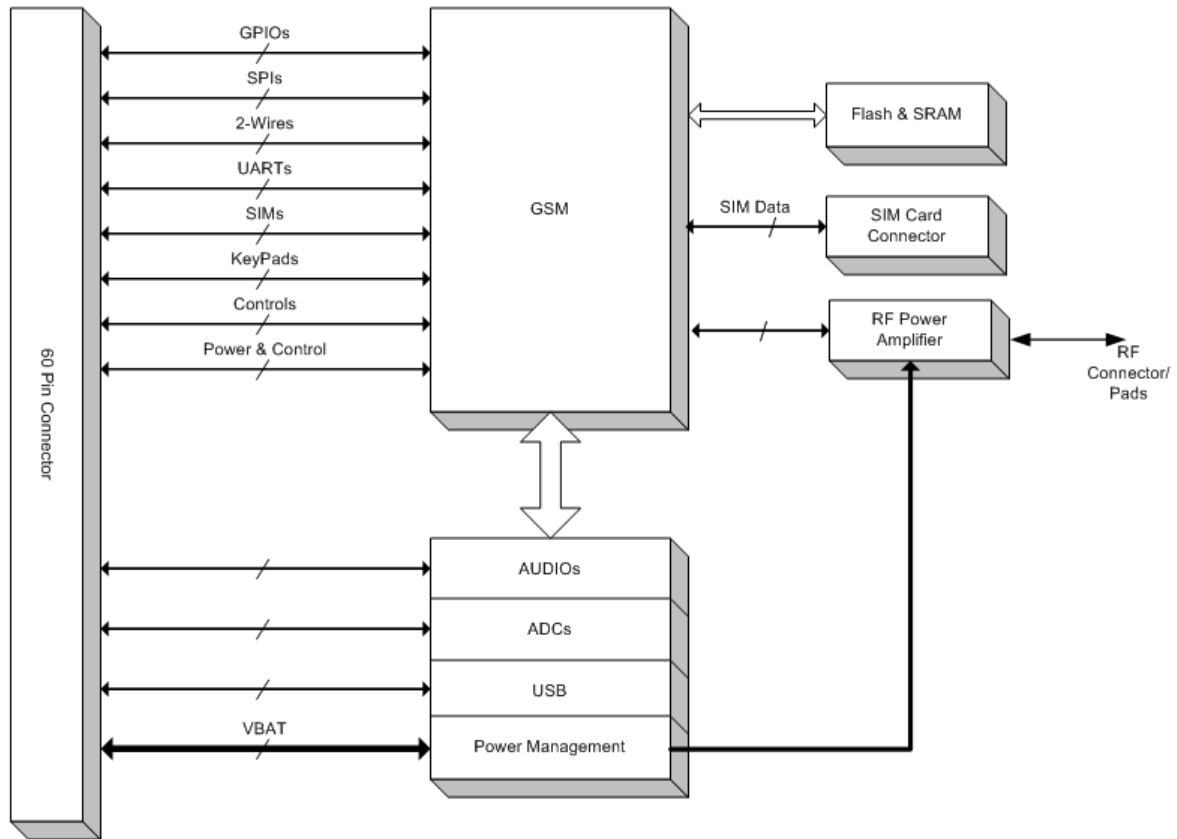

Figure 1: TR-900 Functional Block Diagram

## 4 INTERFACES

### 4.1 General-Purpose Connector (GPC)

The General-Purpose Connector is provided to interface to the TR-900 module. The GPC is Astron 60-pin 0.5mm-pitch board-to-board socket. The part reference is 6091060-252-R. The recommended mating part is 6090060-252-R from Astron.

### 4.2 Power Supply and Ground

The power supply design is one of the key design areas for a GSM terminal due to the burst characteristics of GSM transmission. The supply must be able to deliver very high current peaks in a very short time during a GSM transmit burst, typically up to 2A. During these bursts, it is recommended that the voltage drop does not exceed 400mV. The voltage ripple should not exceed 50mV at frequencies up to 200 kHz and 2mV at frequencies above 200 kHz.

The supply to the module is provided from the dedicated VBAT pins of the GPC. The module's RF power amplifier is supplied directly from VBAT. Power to other parts of the module is regulated internally. The VBAT supply to the module must be externally regulated according to the module's supply input limits.

All four legs of the shield must be soldered onto the target PCB. The ground connection of the target PCB has to go through a full ground plane on the PCB.

The power supply voltage for VBATT is given below:

#### Pin Description

Signal	Pin Number	Type
VBAT	1,2,59,60	Supply Input
GND	3	-

#### Power Supply Voltage

Parameter	Min	Nom	Max	Unit
VBAT	3.2	3.8	5.5	V

**Note:**

*If Vbatt is kept at voltage levels lower than 3.2V, it will automatically power-off.*

*During burst emissions in GSM/GPRS, the power supply must provide high current peaks of at least 2.0A.*

**4.2.1 Power Consumption**

The following abbreviations are used in the state definition of TR-900 module:

Abbreviation	Description
Module NOBAT	Module is not powered by any supply.
Module OFF	Module is powered by the main supply VBAT and maintains only the RTC supply.
Module BACKUP	Module is powered only by the VBACKUP and maintains only the RTC supply.
Module IDLE	Module is registered to the GSM network. The module is ready to send and receive.
Active Voice Call	Connection between two subscribers is in progress. Power consumption depends on network coverage individual settings.
GPRS Data	Module is in GPRS data transfer mode. Power consumption depends on network settings, and uplink / downlink data.
Sleep Mode	Module is powered by the main supply VBAT, only selected supplies are enabled and the module is in low consumption mode. In deep sleep, the clock is switched off except 32kHz.

The power consumption depends on the configuration used. It is for this reason that the following power consumption values are given for each modes.

Operating Mode	Conditions	I <sub>Nom</sub>	I <sub>Max</sub>	Unit
Module OFF/BACKUP		50	100	μA
Module IDLE	DRX=6 (Ave) with SLEEP mode enable	<2.5	-	mA
Active VOICE call	'EGSM – PCL 5 (Ave)	420	460	mA
	DCS/PCS – PCL 0 (Ave)	380	420	mA

GPRS DATA (3Rx/2Tx)	EGSM – PCL 5 (Ave)	420	460	mA
	DCS/PCS – PCL 0 (Ave)	380	420	mA

\*Test Condition :  $T_{amb} = 25^{\circ}\text{C}$ ,  $V_{bat} = 3.8\text{V}$

**Note:**

*If Vbatt is kept at voltage levels lower than 3.2V, it will automatically power-off.*

*During burst emissions in GSM/GPRS, the power supply must provide high current peaks of at least 2.0A.*

### 4.3 Backup Power Supply

Backup supply can be provided to the module. It is used as a backup power supply to the internal Real Time Clock (RTC). This feature is required to maintain the date and time when the module is powered-off to reduce the power consumption.

**Pin Description**

Signal	Pin Number	Type	Description
VBACKUP	5	Supply input	Backup supply to RTC

**Electrical Characteristics**

Parameters	Conditions	Nom	Unit
Output voltage	Backup battery connected on VBACKUP	1.8	V

## 4.4 Battery-Charging Interface (BCI)

This feature controls the charging of Lithium Polymer or Lithium-ion batteries. It can be used to perform functions such as battery pre-charging and battery charging. The battery charging management is currently not available in the TR-900 module. This feature is not enabled in the standard module firmware as it must be customized according to customer's application. Please contact us at iWOW for more information on this battery charging management. As there is no on-board charging circuit available currently, an external charging circuit is recommended to be placed on-board.

**Note:**

*For charger voltage input, connect VBatt to relevant pins of charging IC*

**Pin Description**

Signal	Pin Number	Type	Description
PCHG	4	Analog Output	Pre-charge output current
ICTL	57	Analog Output	Charger external transistor control
VCCS	58	Analog Input	Charging current sense

## 4.5 Analog to Digital Converter (ADC)

The module provides two 10-bit ADC inputs.

These two interfaces can also be used together with the Battery Charging Interface (BCI) for sensing of battery type and battery temperature (i.e. ADIN1 for Battery Type Sensing and ADCIN 2 for Battery Temperature Sensing). The ADC features for BCI are not enabled in the standard module firmware. Please contact us at iWOW for more information on this ADC features.

**Note:**

*An external pull-up resistor of 10K $\Omega$  is required on ADCIN2 if used for purpose other than Battery Temperature Sensing.*

*Connect ADCIN1 and ADCIN2 to GND if not in use.*

### Pin Description

Signal	Pin Number	Type	Description
ADCIN1	6	Analog Input	ADC input 1
ADCIN2	55	Analog Input	ADC input 2

### Electrical Characteristics

Parameters	Conditions	Min	Nom	Max	Unit
Resolution	-	-	10	-	Bits
Reference voltage	-	-	1.75	-	V
Differential non-linearity	-	-2	-	2	LSB
Integral non-linearity	Best Fitting	-2	-	2	LSB
Input Range	-	0		1.75	V
Switching running frequency	-	-	1	-	MHz
Clock Period, t	-	-	1	-	μs
Conversion time	-	-	16.5T + 9.5T	-	
Input Resistance	-	-	-	100	KΩ

## 4.6 ON/OFF Control

The PWON pin is used to switch the module ON or OFF.

### Pin Description

Signal	Pin Number	Type	Description
PWON	9	Input	Module switch ON/OFF

### Electrical Characteristics

Parameters	Conditions	Min	Nom	Max	Unit
High level input voltage, $V_{IH}$	-	0.65VB AT	-	-	V
Low level input voltage, $V_{IL}$	-	-	-	0.35VB AT	V

#### 4.6.1 State Transitions

The following is the state transitions for the TR-900 module.

State	Description
Power-OFF	Module is not powered by any supply, main or backup.
Power-ON	Charged main supply or backup supply is plugged in.
Switch-OFF	Module is powered and switched from ACTIVE or SLEEP state to reach the OFF or BACKUP state.
Switch-ON	Module is powered on and awakened from the OFF state to reach the ACTIVE state.

#### 4.6.2 Switch-On Condition

The module has to be in the OFF state. This condition will switch-ON the module:

- When a falling edge, after debouncing, is detected on the PWON pin. The PWON pin is debounced by embedded hardware. The debounce time is approximately 30ms.
- When a charger voltage is detected at the VCHG pin. This voltage must be above VBAT+0.4V for the switch-ON to occur. This switch-ON condition is available only with the Battery Charging Interface.

There are two cases when this switch-ON sequence does not happen:

- When the main supply is under 3.2V.
- When the system is in BACKUP state (power is supplied via the VBACKUP pin only).

#### 4.6.3 Switch-Off Condition

The module has to be in the ON state. This condition will switch-OFF the module:

- A falling edge signal is detected on the PWON pin after debouncing and the signal remains low for a minimum period of 900ms. The PWON signal must be released back to high after the module has switched-OFF.
- When the level of the main supply VBAT decreases below 2.8V and below the level of the backup supply.

**Note:**

*When the switch-OFF sequence is started, the sequence is completed even if a switch-ON condition occurs.*

## 4.7 Reset Signal

This reset Pin 10 provides an unconditional hardware reset input to the module. A low level signal will trigger the reset of the module. This pin is meant for testing purposes only. When the pin is not used, it can be left unconnected. It is internally pulled up by a 100 k $\Omega$  resistor. A capacitor of value about 15nF can be placed close to the pin on the GPC to improve its ESD shielding.

### Pin Description

Signal	Pin Number	Type	Description
RESET	10	Input	Module reset input. Test only.

**Note:**

*This feature is recommended for testing purpose only.*

## 4.8 VIO Digital Supply Output

This internally regulated digital supply output can be used to supply external peripherals like a LED circuitry. It will only be available after the module is switched-ON and as such, this pin can also be used to signalize the module's state, indicating whether it is in ON or OFF mode.

### Pin Description

Signal	Pin Number	Type	Description
VIO	56	Supply output	Digital supply output

### Electrical Characteristics

Parameters	Conditions	Min	Nom	Max	Unit
Output voltage, VOUT	On mode	1.65	1.8	1.95	V
	LOW POWER mode	1.65	1.85	1.95	V
Rated output current, IOUT	On mode			200	mA
	LOW POWER mode			1	mA

## 4.9 Subscriber Identity Module (SIM) Interface

The SIM card interface is composed of an internally dedicated voltage regulator and I/O level shifters. It is able to support both 1.8V and 3V SIM cards.

It is recommended that the routing traces of the SIM interface lines be kept as short as possible. ESD diodes can be added to the signals connected to the SIM socket to prevent any ESD-related issues. The diodes shall be placed as close to the SIM socket as possible. Also, a decoupling capacitor of about 100nF should be added on the VSIM line near the SIM socket.

### Pin Description

Signal	Pin Number	Type	Description
SIMIO	16	Input/ Output	Data
SIMCLK	17	Output	Clock
SIMRST	43	Output	Reset
VRSIM	44	Output	Internal voltage regulator output
SIMDTC	45	Input	SIM Detect

### Electrical Characteristics

Parameters	Conditions	Min	Nom	Max	Unit
VSIM	SIM 3V	2.7	2.85	2.95	V
	SIM 1.8V	1.65	1.8	1.95	V
SIMDTC, Low level input voltage, $V_{IL}$		-	-	0.54	V
SIMDTC, High level input voltage, $V_{IH}$		1.17	-	-	V
SIMDTC, Debouncing time (SIM-card insertion)		0.5	-	8	Ms
SIMDTC, Debouncing time (SIM-card extraction)		0.5	-	8	Ms

#### 4.9.1 SIM Detection

For SIM detect, when a SIM card is inserted in the SIM cardholder, SIMDTC is tripped and after debouncing, an interrupt is generated. The SIM-card presence detection logic must be active even when the system is in idle mode. The debouncing logic is based on the 32-kHz low-activity clock.

## 4.10 Serial Link (UART) Interfaces

### 4.10.1 UART – Modem port

This port is assigned to the module communication with the host device using AT Commands.

The port integrates two 64-word (9 and 11 bits) receive and transmit FIFOs. The default baud rate is 115200. Transmission parity can be even, odd or none (default). Number of stop bits can be 1 (default), 1.5 or 2. All modem port operations are controllable using hardware flow control signals (default).

If RTS and CTS are not in use, it is recommended to connect the pins together.

If DTR and DSR pins are not used, the pins are to be connected to GND.

**Note:**

*10K $\Omega$  pull up resistor to VIO is required for both UART\_TX and UART\_RTS pins.*

#### Pin Description

Signal	Pin Number	Type	Description
UART_TX	24	Input	DCE Data Receive
UART_RX	37	Output	DCE Data Transmit
UART_CTS	36	Output	Clear To Send. Hardware flow control
UART_RTS	25	Input	Ready To Send. Hardware flow control
RI	19	Output	Ring Indicator
DCD	26	Output	Data Carrier Detect
DTR	35	Input	Data Terminal Ready
DSR	42*	Output	Data Set Ready

## 4.11 USB Interface

The USB interface supports a USB 2.0 Full Speed (12 Mbps/s) and low-speed (1.5 Mbps/s) operations. The USB power line is 5V I/O compliant. It is primarily meant for support flashing of firmware.

**Note:**

*Connection of a 4.7 $\mu$ F Capacitor externally at VBUS for filtering is required.*

### Pin Description

Signal	Pin Number	Type	Description
VBUS	7	Input/ Output	USB VBUS power supply line
ID_USB	8	Input/ Output	USB Connector Identification
USB_DM	53	Input/ Output	USB Data Bus (-ve)
USB_DP	54	Input/ Output	USB Data Bus (+ve)

### 4.11.1 USB Boot

This pin is configured for use only during firmware flashing. LPG will be the default function during module operations.

**Note:**

*External 100K $\Omega$  pull up resistor to VIO pin and 100K $\Omega$  pull down resistor to GND is required for USB\_BOOT to function.*

*If USB\_BOOT is not used, the pull up/down resistors will not be required.*

### Pin Description

Signal	Pin Number	Type	Description	Alternate Function
USB_BOOT	18	Input	USB Boot type during firmware flashing BOOT: -1 for USB -0 for UART	GPIO_1/ DSR

## 4.12 Analog Audio Interfaces

### 4.12.1 Microphone input

The handset differential inputs MICIP and MICIN can be amplified by the differential handset microphone amplifier. The Microphone reference voltage is at 2V.

The microphone uplink path gain is programmable by using AT command and can be set from -12 to +12 dB in 1-dB steps.

#### Pin Description

Signal	Pin Number	Type	Description
MICIN	29	Input	Microphone amplifier input (-ve)
MICIP	30	Input	Microphone amplifier input (+ve)

#### Electrical Characteristics

Parameters	Conditions	Min	Nom	Max	Unit
Maximum differential input range (MICIP – MICIN)	Input 3 dBm0	-	-	32.5	mVrms
Nominal reference level (MICIP – MICIN)	-	-	-10	-	dBm0
Differential input resistance (MICIP – MICIN)	-	-	36	-	KΩ
MICBIAS output voltage	MICBIASLVL bit =0, I <sub>MICBIAS</sub> = 0 to 2mA	1.9	-	2.1	V
	MICBIASLVL bit =1, I <sub>MICBIAS</sub> = 0 to 2mA	2.4	-	2.6	V
MICBIAS rated output current	-	-	-	2	mA

#### 4.12.2 Earphone

The earphone amplifier provides a full differential signal on the EARP and EARN terminals.

The volume control is performed in steps of 1dB from 0 dB to -24 dB. In mute state, attenuation is higher than 40 dB. A fine adjustment of gain is possible at 0 dB or +6 dB in 1 dB steps.

#### Pin Description

Signal	Pin Number	Type	Description
EARP	27	Output	Earphone amplifier output (+ve)
EARN	28	Output	Earphone amplifier output (-ve)

#### Electrical Characteristics

Parameters	Conditions	Min	Nom	Max	Unit
Power supply rejection	1KHz, 100mVpp	-	50	-	dB
Output Swing at EARP-EARN	Amp gain = -11, Distortion ≤ 2%, Load = 120Ω, VSP Input level = +3 dBm0	-	0.98	-	Vpp
	Amp gain = -11, Distortion ≤ 2%, Load = 120Ω, VSP Input level = -5.34 dBm0	-	0.38	-	Vpp
	Amp gain = 1, Distortion ≤ 2%, Load = 120Ω, VSP Input level = +3 dBm0	3.1	3.92	-	Vpp
	Amp gain = 1, Distortion ≤ 2%, Load = 120Ω, Input level = -5.34 dBm0	1.2	1.5	-	Vpp

### 4.12.3 Speaker

Volume control is performed in steps of 1dB from 0 dB to -24 dB. In mute state, attenuation is higher than 40 dB. A fine adjustment of gain is possible at 0 dB or +6 dB in 1 dB steps.

#### Pin Description

Signal	Pin Number	Type	Description
SPKNA	51	Output	Speaker signal (-ve)
SPKPA	52	Output	Speaker signal (+ve)

#### Electrical Characteristic

Parameters	Conditions	Min	Nom	Max	Unit
Hands-free speaker output swing at SPKP-SPKN (differential output), SPKVDD = VBAT	distortion 1% and 8 , SPKVDD = 4.2 V Pout = 340 mW, SPKG = 001 (2.5 dB), VSP input level = +3 dBm0	-	4.65	-	Vpp
Hands-free speaker output swing at SPKP-SPKN (differential output), SPKVDD = VBAT	distortion 1% and 8 , SPKVDD = 4.2 V Pout = 680 mW, SPKG = 000 (8.5 dB), VSP input level = 0 dBm0	-	6.6	-	Vpp
Speaker amplifier power supply rejection	1KHz, 100mVpp	-	80	-	dB

### 4.13 Digital Audio Interface

It can be used for Bluetooth or other digital audio implementations. This feature is not enabled in the standard module firmware. Please contact iWOW for more information on this interface.

#### Pin Description

Signal	Pin Number	Type	Description
MCSI_CK	31	Input/Output	MCSI Clock IO
MCSI_FS	32	Input/Output	MCSI Frame Synchronization
MCSI_RX	33	Input	MCSI Receive Data
MCSI_TX	34	Output	MCSI Transmit Data

### 4.14 Light Pulse Generator (LPG)

The blink period is used to indicate different levels of GSM Network activity.

#### Pin Description

Signal	Pin Number	Type	Description	Alternate Function
LPG	18	Output	Blinking LED control signal	GPIO_4

#### Blinking Characteristics

Module Status	LED activity
In OFF mode	OFF
ON mode, not registered to network	Permanently ON
ON mode	Permanently ON
ON mode, registered to network, communication inactive	Slow Flashing
ON mode, registered to network, communication in progress	Quick Flashing

### Electrical Characteristics

Parameters	Conditions	Min	Nom	Max	Unit
High level input voltage, $V_{IH}$	-	0.65VDD5	-	-	V
Low level input voltage, $V_{IL}$	-	-	-	0.35VDD5	V
High level output voltage, $V_{OH}$	IO = 4mA	VDD5-0.45	-	-	V
Low level output voltage, $V_{OL}$	IO = 4mA	-	-	0.45	V
Output current	-	-	4	-	mA

### 4.15 General Purpose Input Output (GPIO)

The GPIOs are fully programmable either as input or output using AT Commands.

#### Pin Description

Signal	Pin Number	Type	Alternate Function
GPIO_1 / USB_BOOT/DSR	18	I/O	USB BOOT/DSR
GPIO_2/ RI	19	I/O	RI
GPIO_3	20	I/O	BUZZER
GPIO_4/ LPG	42	I/O	LPG

#### Other Shared GPIOs

Signal	Pin Number	Type	Default Function
GPIO_5	15	I/O	KBC4
GPIO_6	21	I/O	SPI_MISO
GPIO_7	22	I/O	SPI_NCS
GPIO_8	26	I/O	DCD
GPIO_9	31	I/O	MCSI_CK
GPIO_10	32	I/O	MCSI_FS
GPIO_11	33	I/O	MCSI_RX
GPIO_12	34	I/O	MCSI_TX
GPIO_13	35	I/O	DTR
GPIO_14	39	I/O	SPI_NCS1
GPIO_15	40	I/O	SPI_MOSI

GPIO_16	41	I/O	SPI_CLK
GPIO_17	46	I/O	KBR4

### Electrical Characteristics

Parameters	Conditions	Min	Nom	Max	Unit
High level input voltage, $V_{IH}$	-	0.65VDD5	-	-	V
Low level input voltage, $V_{IL}$	-	-	-	0.35VDD5	V
High level output voltage, $V_{OH}$	IO = 4mA	VDD5- 0.45	-	-	V
Low level output voltage, $V_{OL}$	IO = 4mA	-	-	0.45	V
Output current	-	-	4	-	mA

### 4.16 Keyboard Interface

The Keyboard interface consists of 10 connections which include 5 row inputs and 5 column outputs. The 5 output lines can alternatively be used as general purpose outputs while the 5 input lines can alternatively be used as general purpose inputs. Please contact iWOW directly for more information on the extended customization to this interface.

### Pin Description

Signal	Pin Number	Type	Default Function
KBC0	11	Output	Keyboard column 0
KBC1	12	Output	Keyboard column 1
KBC2	13	Output	Keyboard column 2
KBC3	14	Output	Keyboard column 3
KBC4	15	Output	Keyboard column 4
KBR0	50	Input	Keyboard row 0. Internal pull-up.
KBR1	51	Input	Keyboard row 1. Internal pull-up.
KBR2	52	Input	Keyboard row 2. Internal pull-up.
KBR3	53	Input	Keyboard row 3. Internal pull-up.

KBR4	54	Input	Keyboard row 4. Internal pull-up.
------	----	-------	-----------------------------------

### Electrical Characteristics

Parameters	Conditions	Min	Nom	Max	Unit
High level input voltage, $V_{IH}$	-	0.65VDD5	-	-	V
Low level input voltage, $V_{IL}$	-	-	-	0.35VDD5	V
High level output voltage, $V_{OH}$	IO = 4mA	VDD5-0.45	-	-	V
Low level output voltage, $V_{OL}$	IO = 4mA	-	-	0.45	V
Output current	-	-	4	-	mA

#### 4.16.1 Implementation of a 5x5 keyboard

If a key button of the keyboard matrix is pressed, the corresponding row and column lines are shorted together. To allow key press detection, all input pins (KBR) are pulled up to VCC and all output pins (KBC) are driving a low level. Any action on a button will generate an interrupt thru the input pin to the micro-controller that will, as answer, scan the column lines. The scanning is a digital one with the debouncing done in the module itself. A 33pF capacitor is recommended for each of the keypad input lines to eliminate ghosting effect. ESD diodes are also recommended to eliminate ESD issues.

Keyboard implementation diagram is shown below:

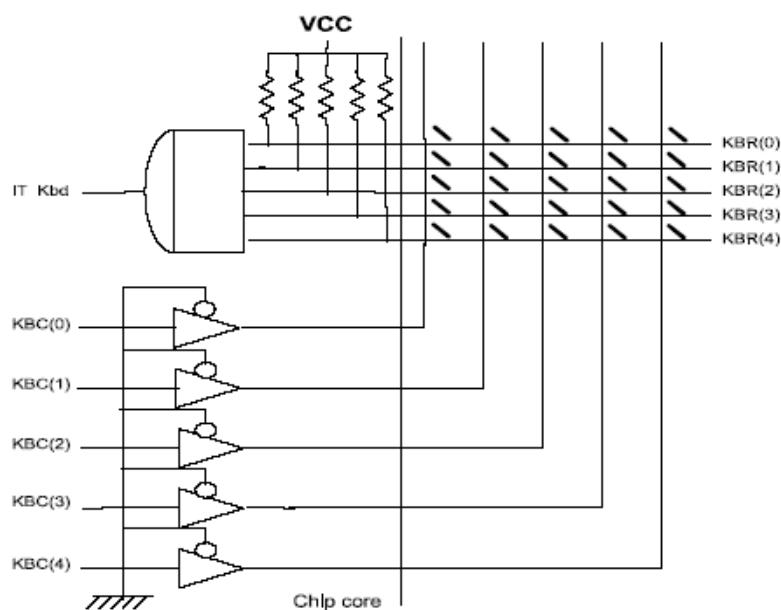

## 4.17 2-Wire Serial Interface

This is a half-duplex serial port using 2-line for data transmission consisting of SDA data signal and SDL clock signal. It can transfer at speeds up to 400Kbits/s (fast-mode).

This feature is not enabled in the standard module firmware as it requires a certain level of firmware customization depending on its intended application. Please contact iWOW for more information on this interface.

**Note:**

*Supports 1.8V I2C compliant devices.*

### Pin Description

Signal	Pin Number	Type	Default Function
I2C_SDA	23	Input/ Output	Two wire interface serial bi-directional data
I2C_SCL	24	Input/ Output	Two wire interface Master serial clock

### Electrical Characteristics

Parameters	Conditions	Min	Nom	Max	Unit
High level input voltage, (SDA and SCL), $V_{IH}$	-	-	-	3	V
Low level input voltage(SDA and SCL), $V_{IL}$	-	0	-	-	V

## 4.18 Serial Parallel Interface

The SPI bus includes clock (SPI\_CLK), I/O (SPI\_MISO, SPI\_MOSI) and chip select (SPI\_NCS0, SPI\_NCS1) signal. This feature is not enabled in the standard module firmware as it requires a certain level of firmware customization depending on its intended application. Please contact iWOW for more information on this interface.

**Note:**

*Supports 1.8V SPI compliant devices.*

### Pin Description

Signal	Pin Number	Type	Description
SPI_CLK	41	Input/ Output	MSSPI serial clock
SPI_MISO	21	Input/ Output	SPI Data: Master in/ Slave out I = MSSPI serial data master-in O = MSSPI serial data slave-out
SPI_MOSI	40	Input/ Output	SPI data: Master out/Slave in O = MSSPI serial data master-out I = MSSPI serial data slave-in

### 4.18.1 SPI Address 0

#### Pin Description:

Signal	Pin Number	Type	Description
SPI_NCS0	22	Output	MSSPI chip select 0 output

### 4.18.2 SPI Address 1

#### Pin Description:

Signal	Pin Number	Type	Description
SPI_NCS1	39	Output	MSSPI chip select 1 output

## 4.19 Buzzer Interface

The digital buzzer on Pin 20 (shared function with GPIO\_3) generates a modulated frequency signal for an external buzzer up to 5K Hz. This feature is not enabled in the standard module firmware. Please contact us at iWOW for more information on this interface.

## 4.20 RF interface

### 4.20.1 Connections

The TR-900's RF interface has a characteristic impedance of  $50\Omega$ . The matching networks for an external antenna connection are not included in the module and should be placed on the host application.

Two methods of RF connections are possible to the host's application antenna.

### 4.20.2 Coaxial Receptacle

An ultra-miniature coaxial receptacle is provided on the bottom side of the module (60-pin connector side). For this receptacle, Harwin's UMC-series connector is adopted. Its part reference is UMCR-2250005R.

### 4.20.3 RF Pad for Coaxial Cable

An RF pad, along with two ground pads, is provided on the top side of the module (along iWOW logo) for direct connection to an antenna or coaxial cable. Please refer to the mechanical drawing for the location and dimensions of these pads.

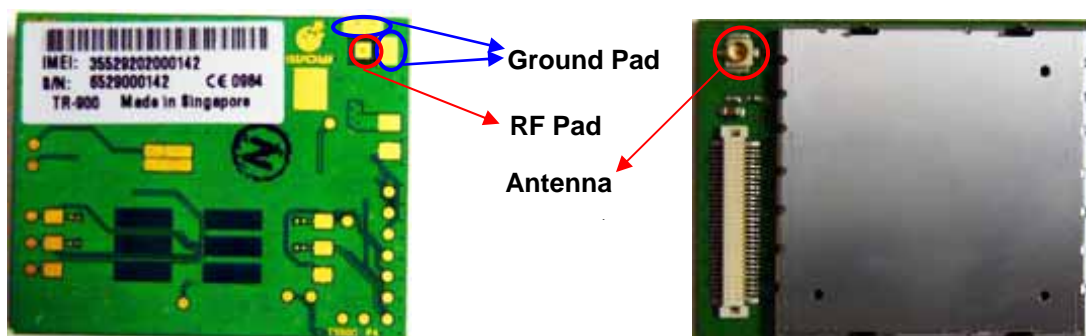

#### 4.20.4 RF Performance

Frequency Bands	RF Sensitivity (dBm)
GSM 850/EGSM 900	-104dBm
DCS1800/ PCS1900	-102dBm

## 5 PINS DESCRIPTION

Pin	Name	I/O	Description	Alternate Functions
1	VBAT	I	Main Battery Voltage	-
2	VBAT	I	Main Battery Voltage	-
3	GND	-	Ground	-
4	PCHG	O	Pre-charge output current	-
5	VBACKUP	I	Backup Battery for RTC	-
6	ADCIN1	I/O	ADC input 1 (Battery type)	-
7	VBUS	I/O	USB VBUS power supply line	-
8	ID_USB	I/O	USB connector identification	-
9	PWON	I	External switch-on event (ON button)	-
10	RESET	I	Module reset input. Test only.	-
11	KBC0	O	Keypad Matrix Column 0	-
12	KBC1	O	Keypad Matrix Column 1	-
13	KBC2	O	Keypad Matrix Column 2	-
14	KBC3	O	Keypad Matrix Column 3	-
15	KBC4	O	Keypad Matrix Column 4	GPIO_5
16	SIM_IO	I/O	IO for SIM interface	-
17	SIM_CLK	O	Clock for SIM interface	-
18	GPIO_1	I	General Purpose IO	USB_BOOT/DSR
19	GPIO_2	I/O	General Purpose IO	RI
20	GPIO_3	I/O	General Purpose IO	BUZZER
21	SPI_MISO	I/O	SPI Data: Master in/ Slave out I = MSSPI serial data master-in O = MSSPI serial data slave-out	GPIO_6
22	SPI_NCS0	I/O	SPI chip select 0 output	GPIO_7
23	I2C_SDA	I/O	Two wire interface serial bi-directional data	-
24	TXD	I	Transmit serial data	-
25	RTS	I	Request to send	-
26	DCD	I/O	Data Carrier Detect	GPIO_8
27	EARP	O	Earphone positive output	-
28	EARN	O	Earphone negative output	-
29	MICIP	I	Microphone positive input	-
30	MICIN	I	Microphone negative input	-
31	MCSI_CK	I/O	MCSI Clock I/O	GPIO_9
32	MCSI_FS	I/O	MCSI Frame synchronization I/O	GPIO_10

33	MCSI_RX	I	MCSI receive data	GPIO_11
34	MCSI_TX	O	MCSI transmit data	GPIO_12
35	DTR	I	Data terminal ready	GPIO_13
36	CTS	O	Clear to send	-
37	RXD	O	Receive serial data	-
38	I2C_SCL	I/O	Two wire interface Master serial clock	-
39	SPI_NCS1	O	SPI chip select 1 output	GPIO_14
40	SPI_MOSI	I/O	SPI data: Master out/Slave in O = SPI serial data master-out I = SPI serial data slave-in	GPIO_15
41	SPI_CLK	I/O	SPI serial clock	GPIO_16
42	GPIO_4	I/O	General Purpose IO	LPG
43	SIM_RST	O	Reset for SIM interface	-
44	VRSIM	PWR	USIM I/O Bus Supply	-
45	SIMDTC	I	SIM-card insertion/removal detection	
46	KBR4	I	Keypad Matrix Row 4	GPIO_17
47	KBR3	I	Keypad Matrix Row 3	-
48	KBR2	I	Keypad Matrix Row 2	-
49	KBR1	I	Keypad Matrix Row 1	-
50	KBR0	I	Keypad Matrix Row 0	-
51	SPKNA	O	Speaker negative output	-
52	SPKPA	O	Speaker positive output	-
53	USB_DM	I/O	USB data bus (negative terminal)	-
54	USB_DP	I/O	USB data bus (positive terminal)	-
55	ADCIN2	I/O	ADC input 2 (Battery temperature)	-
56	VIO	O	Internal Regulated Output voltage	-
57	ICTL	O	USB external pass transistor control (Charger)	-
58	VCCS	I	Charge current sense	-
59	VBAT	I	Main Battery Voltage	-
60	VBAT	I	Main Battery Voltage	-

## 6 60-PIN CONNECTOR

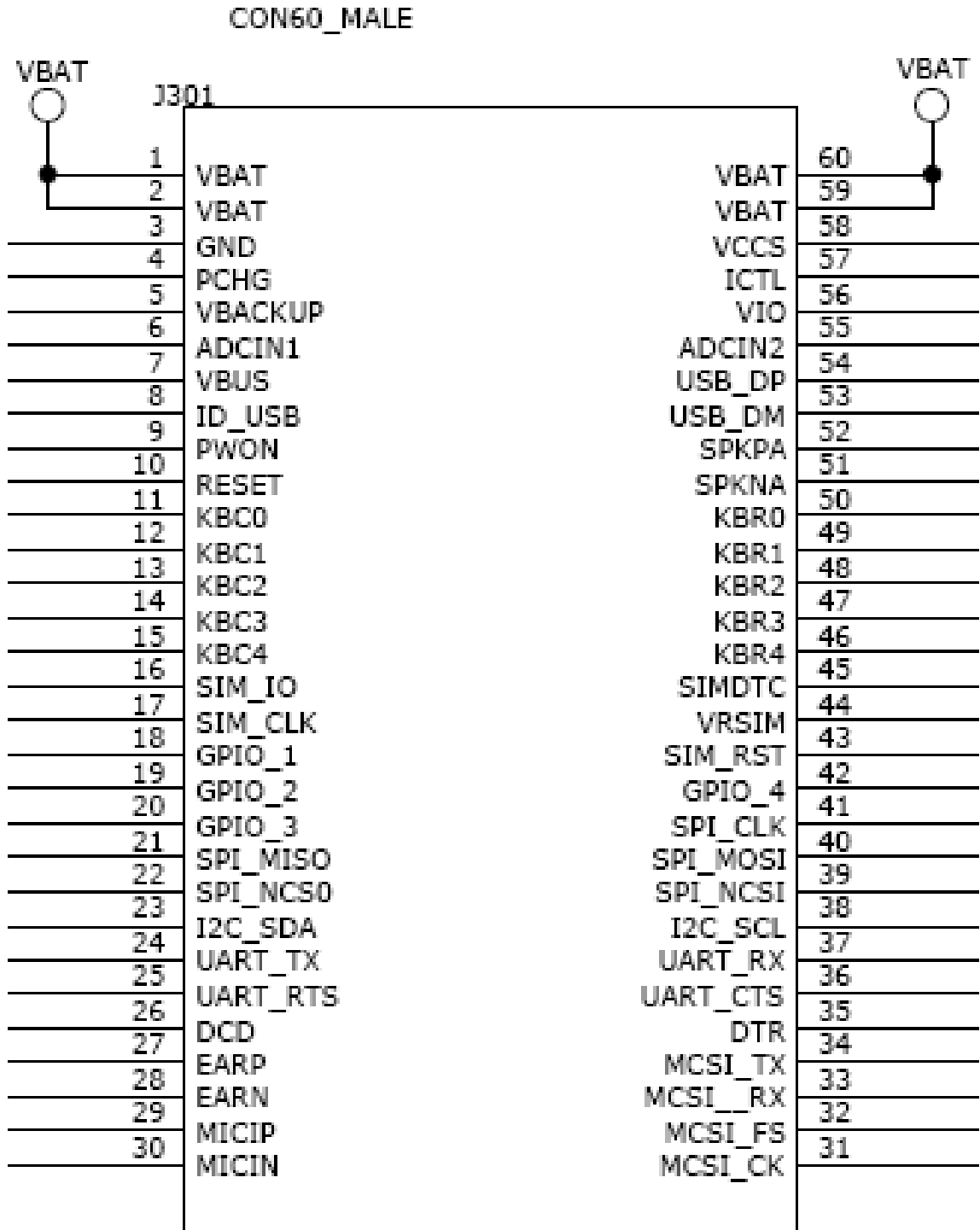

## 7 MECHANICAL DRAWING

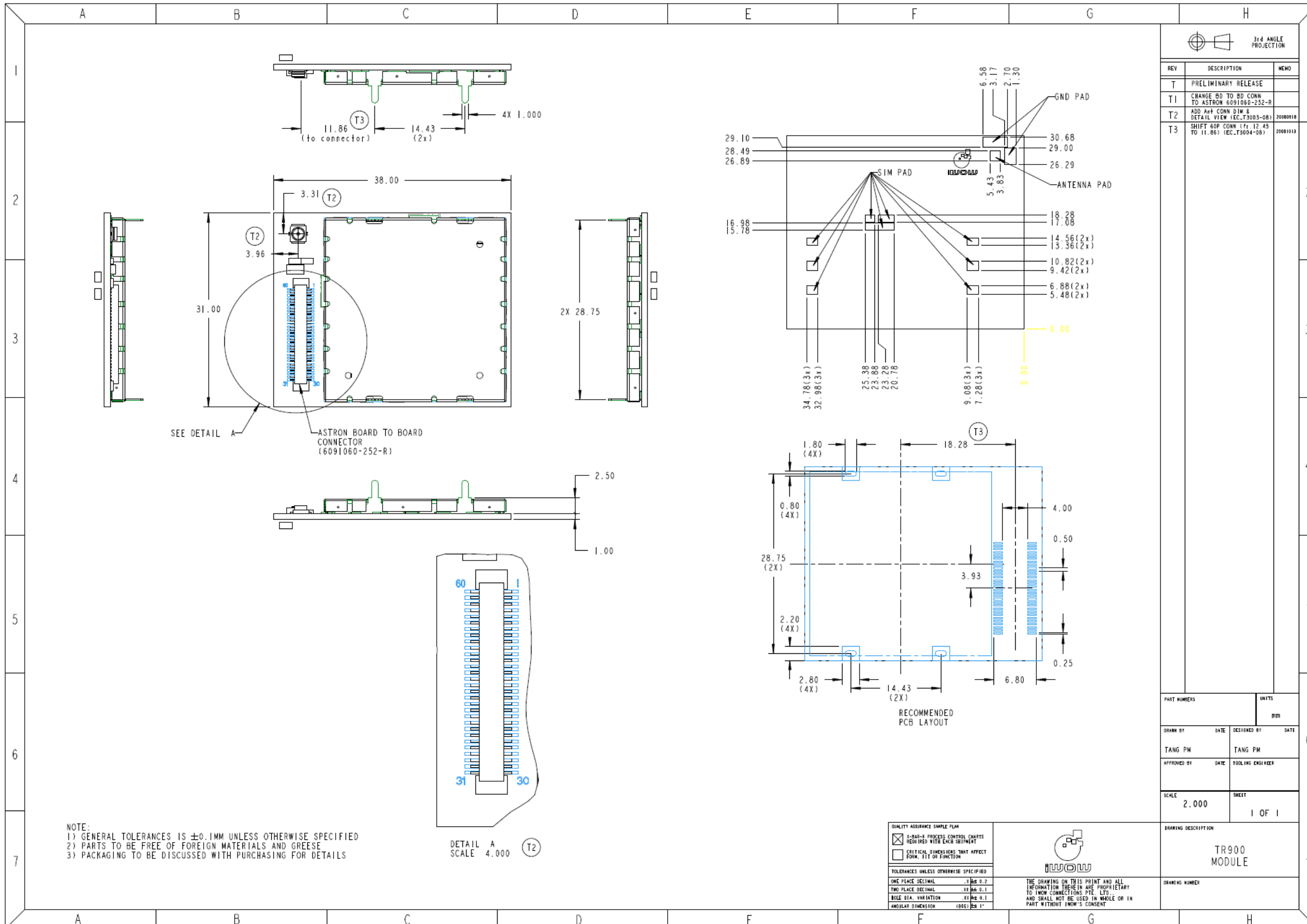

## 8 SUPPORT/ CONTACT US

For distributor clients, please contact your respective distributor FAE.

For direct clients, please contact iWOW FAE (Technical Support Department) or email us at [technicalsupport@iwow.com.sg](mailto:technicalsupport@iwow.com.sg).

For general enquiries please contact us at:

iWOW Connections Pte Ltd  
1 Lorong 2 Toa Payoh, #04-01  
Yellow Pages Building  
Singapore 319637  
Office: (65) 6748 8123  
Fax : (65) 6748 2668  
Email: [sales@iwow.com.sg](mailto:sales@iwow.com.sg)  
Website: <http://www.iWOW.com.sg>

## APPENDIX A: RELIABILITY TEST SPECIFICATION

Test No	Title	Test Conditions	Test Items*
1	Operating Test - High Temperature	+60°C; 250 hrs Vcc (max): 5.5V	Visual Inspection Electrical Test
2	Operating Test - High Temperature	+40°C/95%RH; 250 hrs; Vcc (max): 5.5V	Visual Inspection Electrical Test
3	Storage Test - High Temperature	+80°C; 250 hrs	Visual Inspection Electrical Test
4	Storage Test - Low Temperature	-30°C; 250 hrs	Visual Inspection Electrical Test
5	Drop Test	2.3ft drop; 6 planes; 1x/ plane; at room temperature; on concrete floor, total 6 cycles	Visual Inspection Electrical Test
6	Thermal Shock Test	-40°C/+85°C; dwell for 30min; 50 cycles	Visual Inspection Electrical Test
7	Vibration Test	Freq: 10Hz to 55Hz; Amplitude: 1.5mm; Direction: X, Y & Z; 2hrs each, storage	Visual Inspection Electrical Test

**Note:**

**Electrical Test**

Electrical test will run through functionality check and RF characteristics tests. Functionality test is a test that using TR-900 module at using Development Starter Kit and universal radio communication tester to make a live call and check on basic AT command. RF characteristics tests shall include the following:

- Average Burst Power
- Template Matching
- Timing Error
- Phase Error peak
- Frequency Error
- Rx Level
- Spectrum due to modulation
- Spectrum due to switching
- RX test (BBB / Fast BER)

**Visual Inspection**

The visual inspection is done on the module after performing the test. These include interior cracks, loose or missing components, signs of contamination or dendrite growth, and potential assembly related issues.